

### PACK CONTENTS

- 1 x OS-BASE
- 2 x T7 Alloy Mounts
- 2 x M8 60mm bolts
- 7 x M5 washers
- 3 x M5 20mm bolts
- 4 x 95mm Bolt-on Loops

### TOOLS REQUIRED

- Torx driver T-40
- Torx driver T-15
- Thread Lock



### BEFORE YOU CAN FIT THE OS-BASE TO THE BIKE YOU WILL NEED TO MAKE SOME MINOR ADJUSTMENTS TO THE BIKE HARDWARE

Remove the 2 rear Yamaha hook mounts and replace with the new Kriega T7 Alloy Mounts using the 2 x 60mm M8 bolts provided. We recommend using thread lock on these bolts. ALLOW THE THREAD LOCK TO CURE BEFORE USE (24hrs)

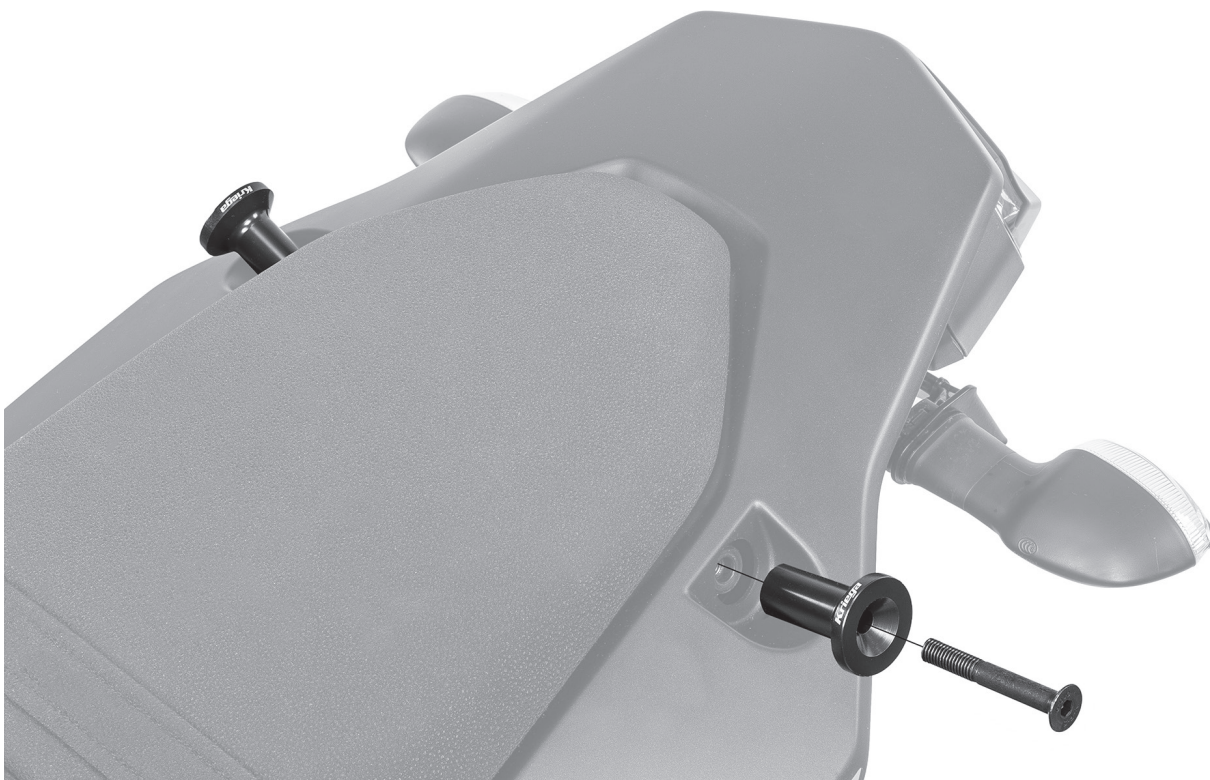

## FIT A PAIR OF OS-ADV PACKS TO THE OS-BASE BEFORE INSTALLING THE COMPLETE SET-UP ON THE BIKE.

Choose a pair of OS-PACKS to meet your carrying capacity requirements:

2 x OS-6 = 12 litres

2 x OS-12 = 24 litres

2 x OS-18 = 36 litres

The modular system allows packs to be changed out to suit your riding needs. There are also options to add an additional centre pack (see **fig B**) or mount one of the OS-PACKS as a stand alone pack for single day rides without the OS-BASE.



To fit an OS-PACK start by threading the roll-top quick release strap through the top loop. (see **fig A**)

Push the top 2 loops on the rear of the bag through the top 2 slots on the OS-BASE and hook-on the compression straps.

Push the bottom 2 loops on the rear of the bag through the corresponding 2 slots on the OS-BASE depending on which size pack and hook-on the compression straps.

Then repeat on the other side. Once the OS-PACKS are connected, you have your SET-UP ready to fit onto the bike.

**fig A**



**EXAMPLE OS-6 FITTING**

## MOUNTING OS-BASE SET-UP ON THE BIKE

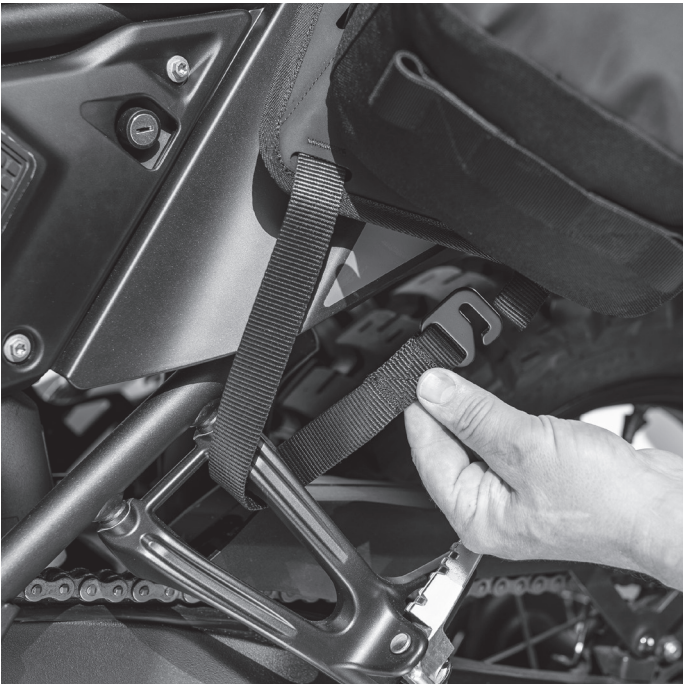

**1** Lay the OS-BASE over the motorcycle seat, forward from the final fitting position. Pass the front hook strap down through the middle of the rear footpeg mount and attach the hook to the web loop so the hook is pointing down. Repeat on the other side.



**2** Set the top straps to the longest length and loop over the alloy mounts on each side.



**3** Standing at the rear of the bike hold both loose straps ends and pull until the OS-BASE is firmly mounted on the seat. A strong tap downwards on each OS-PACK will help the OS-BASE slide further onto the seat.



**4** Once the OS-BASE is tight, tuck the loose strap ends behind each alloy mount.

You are ready to go.

To remove, simply loosen the straps and unhook, the complete set-up is off the bike in seconds.

## MOUNTING A CENTRE PACK

The TENERE BOLT-ON LOOPS included bolt-on to the bike frame under the seat and provide 4 hook-on points for a stand alone OS-PACK or US-Drypack.

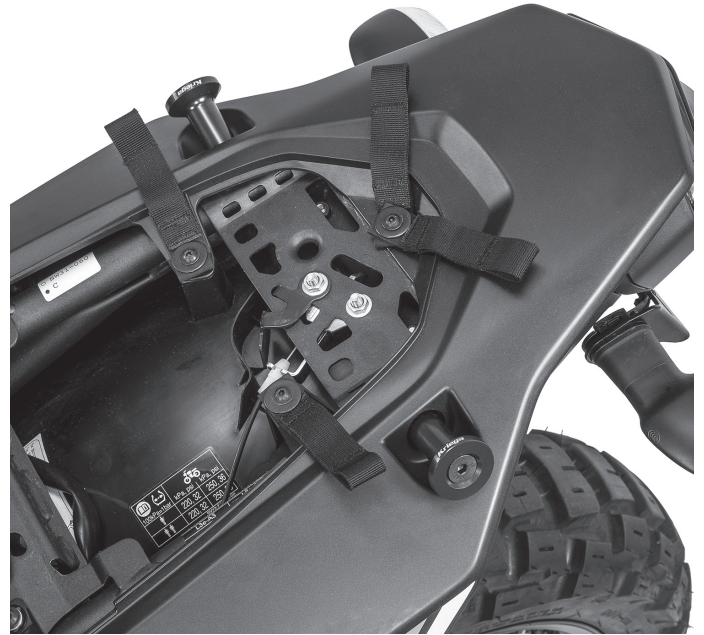

Used in conjunction with the additional loops on the OS-BASE they provide various mounting locations for a 3 or more bag set-up.

To fit remove the seat and unscrew the 3 x Yamaha body panel bolts. Slide an M5 washer inside the hypalon end of each bolt-on loop. Place another washer on top and screw one on either side using the 20mm M5 bolts provided. Put 2 loops together, add another washer on top and screw in the rear centre position as illustrated above. Replace the seat.

fig B

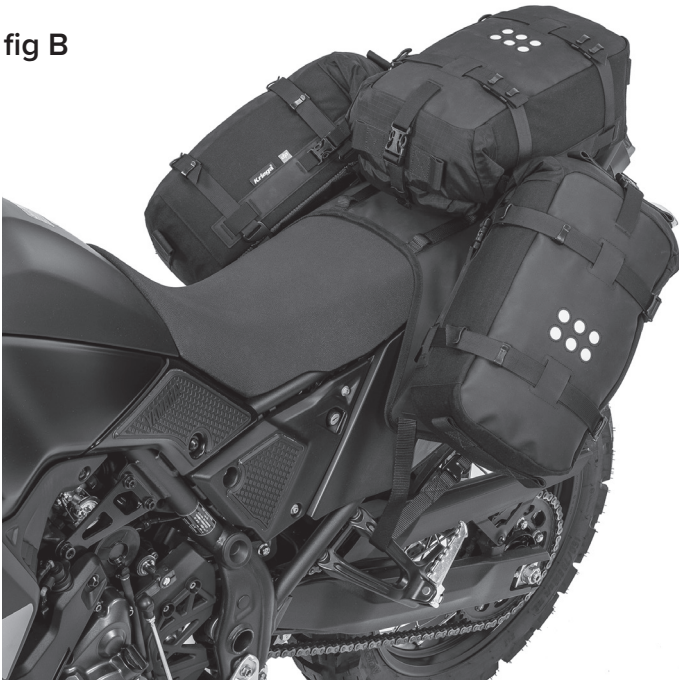

### BODYWORK DAMAGE DISCLAIMER

Even though most of the OS-BASE mounts on the seat, the sides can rub against the plastic side panels of the bike, resulting in minor abrasion. This can be further exaggerated if mud and dust get in between the OS-BASE and the plastics. We strongly recommend applying a clear adhesive protective sheet to where abrasion may occur on your motorcycle.

*It is the owner's responsibility to ensure the OS-BASE is attached in such a way that it does not damage or put at risk the owner or the property of the owner. Do not exceed the UK legal speed limit. This product has only been tested for up to UK road legal speeds.*

**Kriega**<sup>®</sup>